

ELEVATION

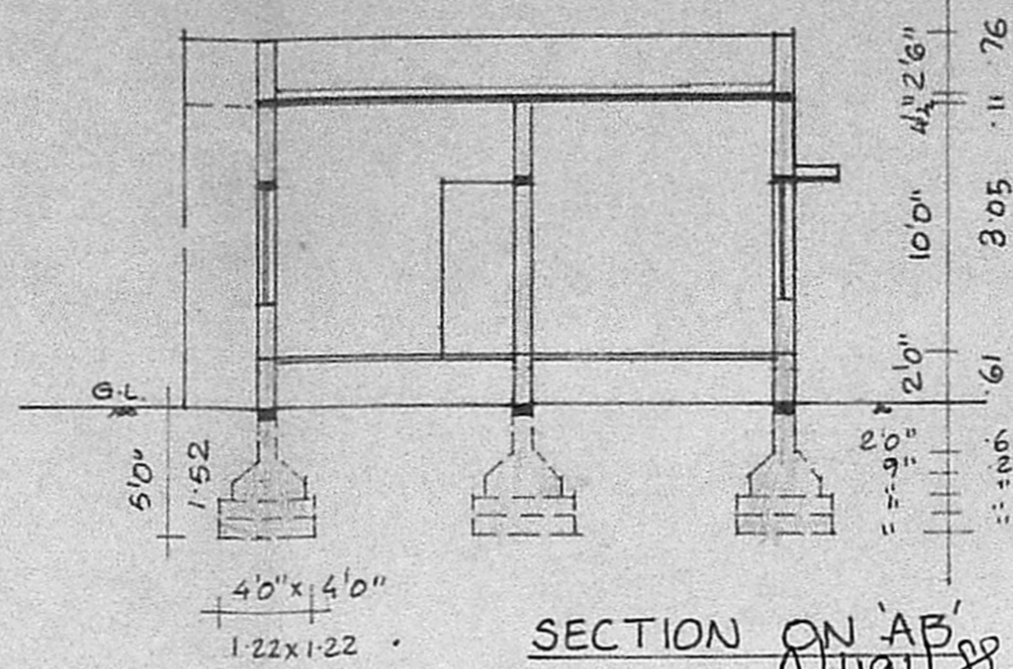

SECTION ON 'AB'

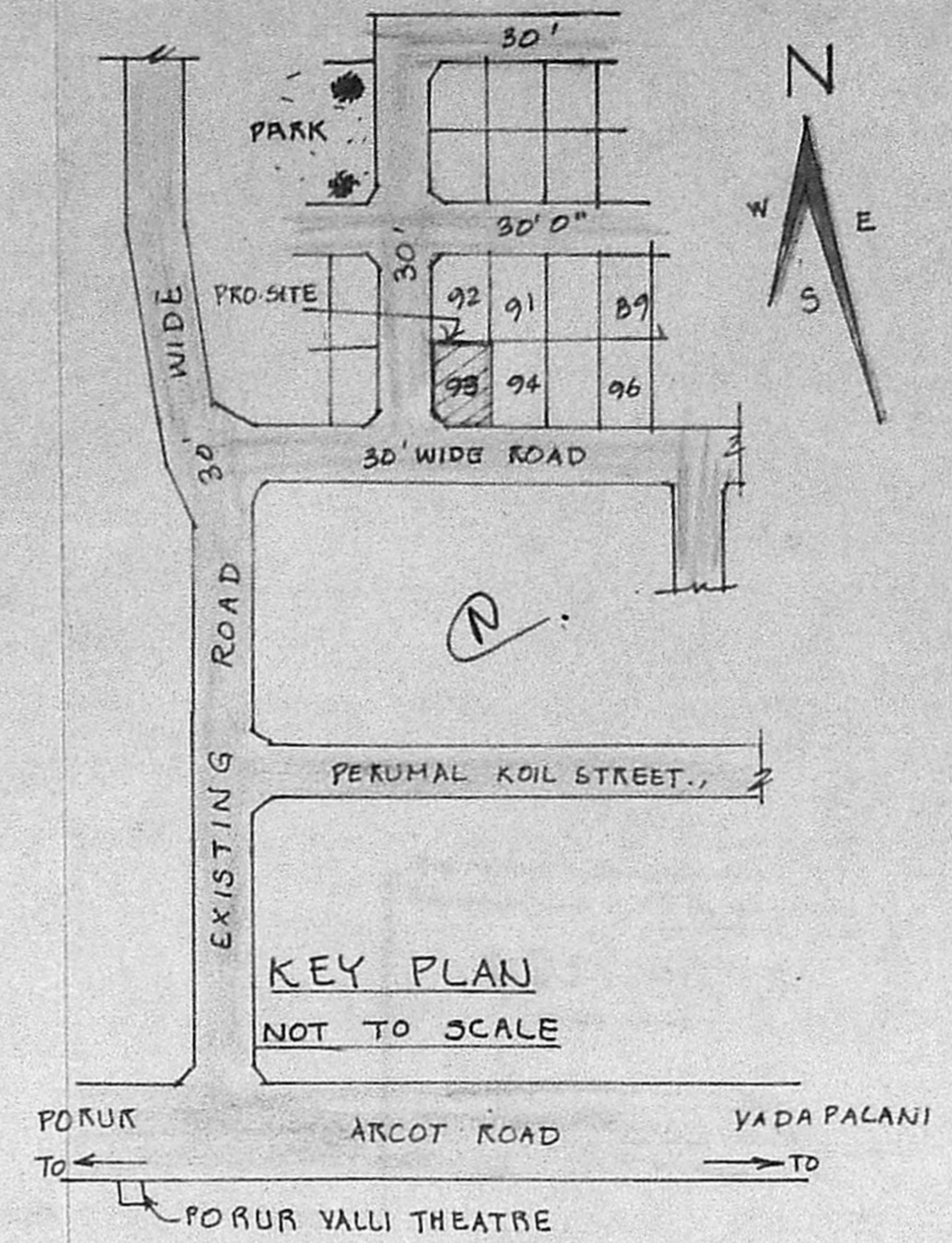

KEY PLAN
NOT TO SCALE

5' 5'0" 4' 4' 1/2" 11'0" 5'
23 1-52 11 1-41 23 3-35 23

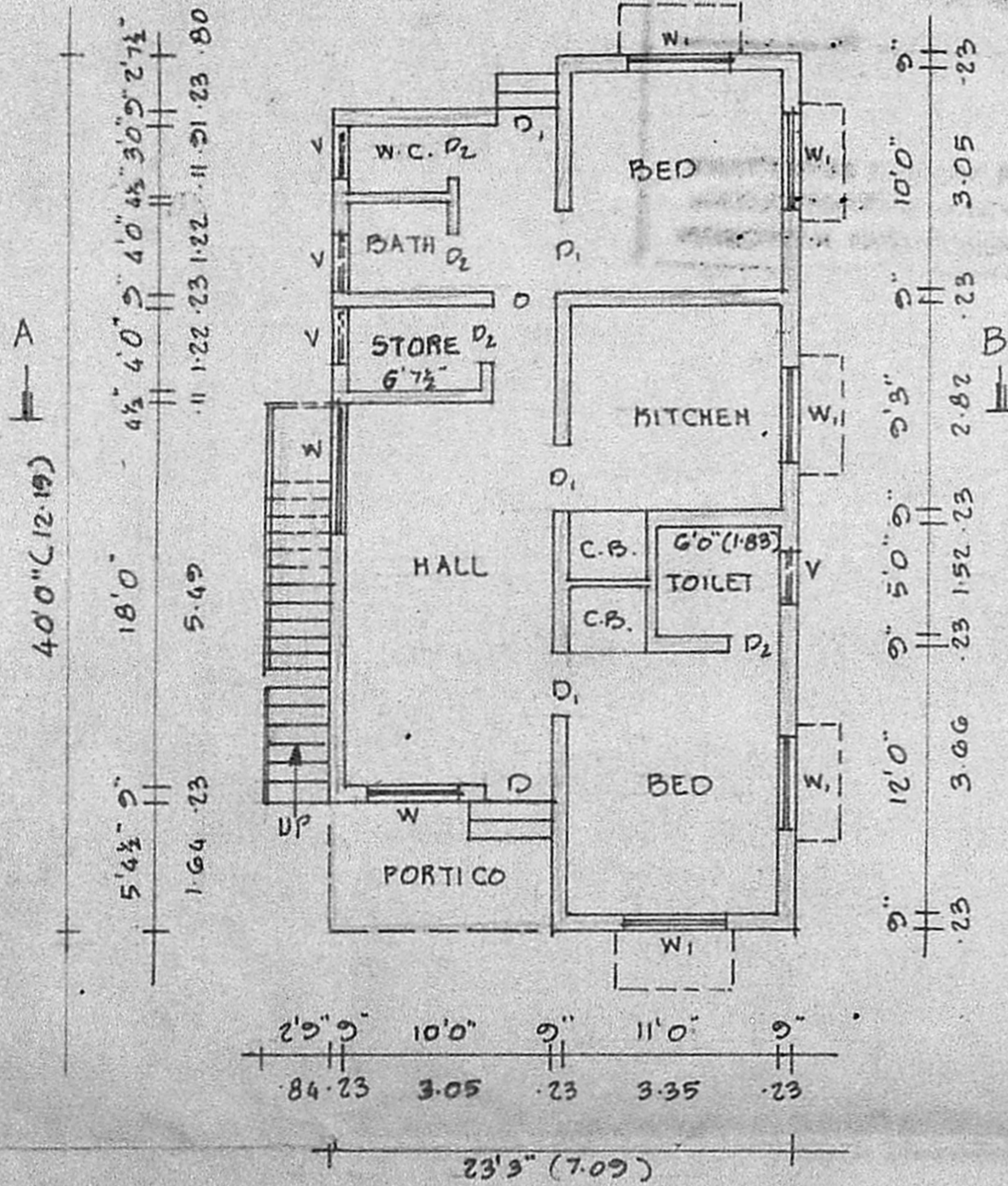

PLAN

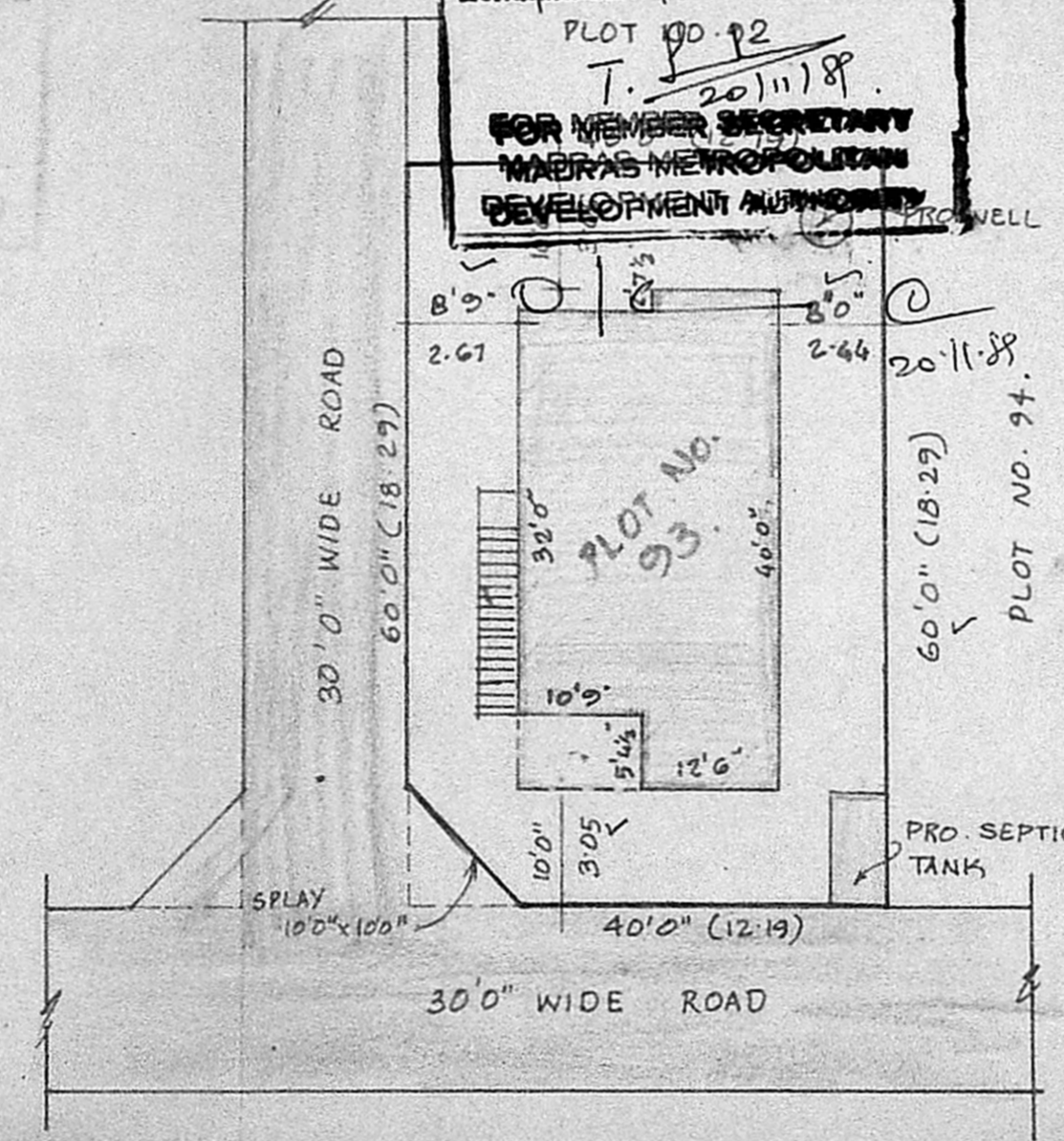
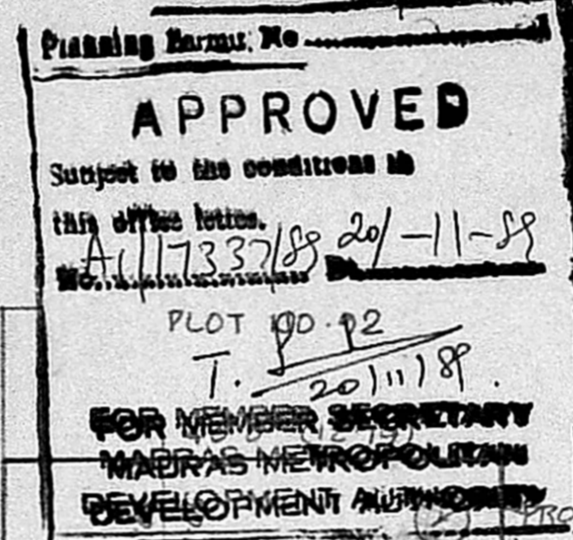

SITE PLAN

SCALE: (1"=16'0" 1:200)

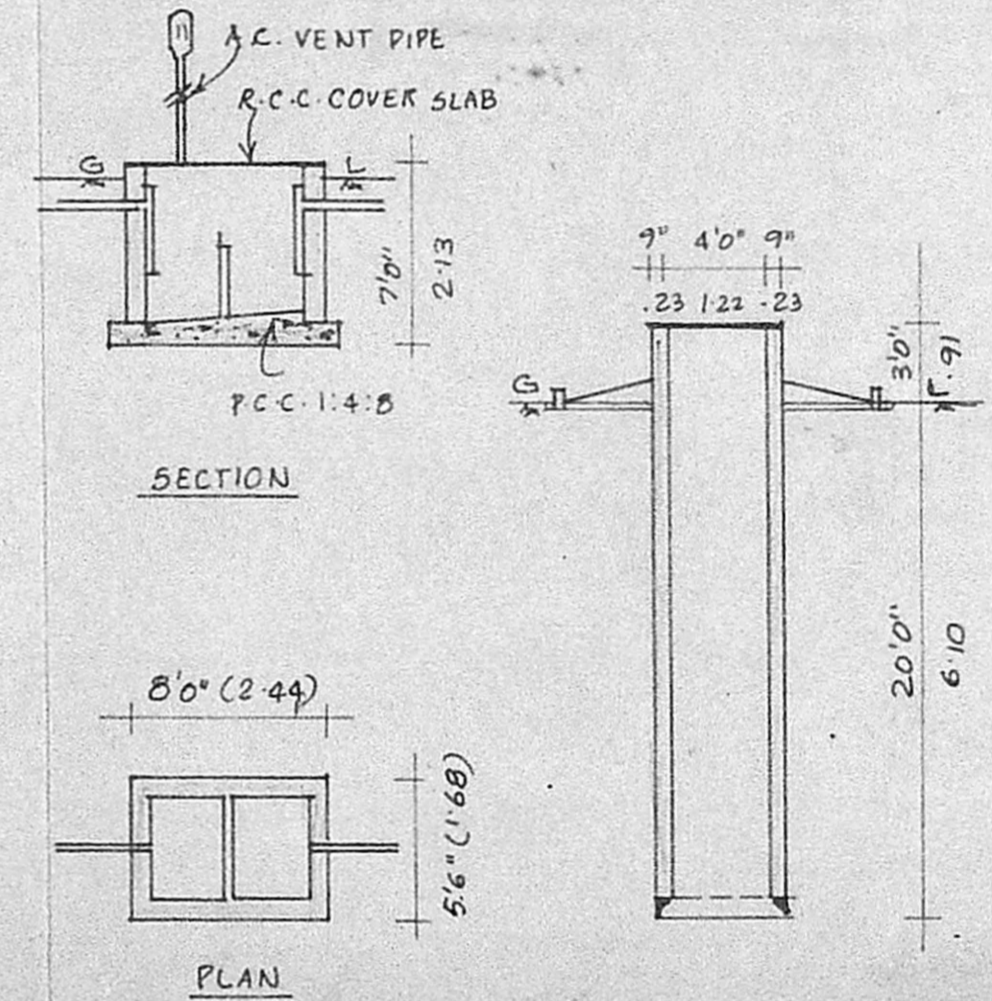

DETAILS OF SEPTIC TANK AND WELL

PLAN SHOWING THE PROPOSED DWELLING HOUSE AT PLOT NO. 93, 'METRO NAGAR' ALAPAKKAM VILLAGE, IN S. NO. 460/2A AND 469/1B, MADURAVOYAL, CHINGLEPUT DISTRICT. SCALE 1" 8'0" (1:100)

LAYOUT APPROVED IN P.P.D NO. 40/87 I.O.

PLOT AREA : 2400 SQ.FT 222.96 SQ.M.
PLINTH AREA : 844 SQ.FT 78.41 SQ.M.
PLOT COVERAGE : 38%
PORTICO AREA : 58 SQ.FT. 5.39 SQ.M.

SPECIFICATIONS :

FOUNDATIONS AND LEVELLING COURSE ARE IN P.C.C. 1:4:8 MIX. BRICK WORK IN C.M. 1:5 MIX. REINFORCED CEMENT CONC WORKS IN 1:2:4 MIX. PLASTERING THE WALLS IN CEMENT MORTAR 1:4 MIX. CEILING AND FLOOR FINISHING IN C.M. 1:3 MIX. WEATHERING COURSE WITH TWO LAYERS OF FLAT TILES LAID IN CEMENT MORTAR 1:4 MIX. DOORS AND WINDOWS ARE IN WELL SEASONED WOOD WITH TWO COATS OF ENAMEL PAINT. WHITE OR COLOUR WASHING FOR WALLS.

SCHEDULE OF JOINERIES

D	DOOR	3'3" x 7'0"	(1.00 x 2.13)
D ₁	DOOR	3'0" x 7'0"	(0.91 x 2.13)
D ₂	DOOR	2'6" x 7'0"	(0.76 x 2.13)
W	WINDOW	6'0" x 4'6"	(1.83 x 1.37)
W ₁	WINDOW	4'6" x 4'6"	(1.37 x 1.37)
W ₂	WINDOW	3'0" x 4'6"	(0.91 x 1.37)
V	VENTILATOR	2'6" x 1'6"	(0.76 x 0.45)

PROPOSAL
ROADS
SITE BOUNDARY LINE

V. Sivasubramania.
OWNER: (V. SIVASUBRAMANIAN) - M.F.L.

V. Venkatesan

V. VENKATESAN, B.E., M.Sc., M.L.A.
CIVIL ENGINEER
Class I Licensed Surveyor No. 6
CORPORATION OF MADRAS
No. 3, Paper Mills Road, First Floor
Near Perambur Church, Madras-11